

# Telecrane Radio Remote Control

## F24 Joystick

### Technical Manual

Rev. 1a  
January 18, 2006



Intercontinental Technologies Ltd. 558 Plate Drive Bldg. #2, East Dundee, IL 60118  
Ph: 847-426-9597, Fax: 847-426-9724, TELECRANE.COM

**This Page Intentionally Left Blank**

# Telecrane F24-J Manual

<b>Section</b>		<b>Page</b>
	General Specifications	5
1.0	Warranty/FCC Approval Information	6
2.0	Installation Instructions	7
3.0	Operation Instructions	8
4.0	Safety	9
5.0	Troubleshooting	11
6.0	Transmitter Function Settings..	12
7.0	Receiver Function Settings	13
8.0	Programming Options	14
9.0	Product Options	15
10.0	Receiver Wiring Diagram	17
11.0	Program and Button Labeling	19

**This Page Intentionally Left Blank**

**Technical specifications for: F24-J**

**Receiver input voltage:** 110 volts AC.

Other Input voltages available 220 VAC, 12V AC/DC, 24 VAC/DC

**Temperature:** -35 deg C to 75 deg C (-31 deg F to 167 deg F)

**Receiver relay ratings:** The receiver relays are rated at 10 amps at 250 volts AC. All COM wires are fused at 10A. *The total current drawn through the receiver relays (through the COM wire) must not exceed 10A.*

**Frequency generation:** Crystal (plug-in)

**Transmitter and receiver housing material:** 30% glass fiber-reinforced nylon-6

**Transmitter joysticks:** 2 joysticks operating a total of 4 axis motions. Full 360-degree range of motion. Rated for 10 million cycles.

**Transmitter dials:** 2 On/Off dials and 2 A, B dials.

**Transmitter button life:** Tested to 2,000,000 operations

**Control range:** 500+ feet

**Transmitter batteries:** 4 AA alkaline batteries.

Channel	Frequency	Channel	Frequency	Channel	Frequency	Channel	Frequency
1	310.0325	11	312.7075	21	315.3825	31	318.0575
2	310.3000	12	312.9750	22	315.6500	32	318.3250
3	310.5675	13	313.2425	23	315.9175	33	318.5925
4	310.8350	14	313.5100	24	316.1850	34	318.8600
5	311.1025	15	313.7775	25	316.4525	35	319.1275
6	311.3700	16	314.0450	26	316.7200	36	319.3950
7	311.6375	17	314.3125	27	316.9875	37	319.6625
8	311.9050	18	314.5800	28	317.2550	38	319.9300
9	312.1725	19	314.8475	29	317.5225		
10	312.4400	20	315.1150	30	317.7900		

Channel	Frequency	Channel	Frequency	Channel	Frequency	Channel	Frequency
112	428.5350	123	431.4775	134	434.4200	145	437.3625
113	428.8025	124	431.7450	135	434.6875	146	437.6300
114	429.0700	125	432.0125	136	434.9550	147	437.8975
115	429.3375	126	432.2800	137	435.2225	148	438.1650
116	429.6050	127	432.5475	138	435.4900	149	438.4325
117	429.8725	128	432.8150	139	435.7575		
118	430.1400	129	433.0825	140	436.0250		
119	430.4075	130	433.3500	141	436.2925		
120	430.6750	131	433.6175	142	436.5600		
121	430.9425	132	433.8850	143	436.8275		
122	431.2100	133	434.1525	144	437.0950		

## 1.0 Warranty:

Intercontinental Technologies, Ltd. (ITL) guarantees that this product meets its published specifications at the time of shipment. This equipment is warranted against defects in material and manufacturing for a period of **one year** from the date of shipment. During the warranty period, ITL will repair or replace defective components at no charge, if the failure of the product was due to defective material or manufacturing. For warranty service, the product must ultimately be returned to ITL. The buyer must pay shipping charges to the ITL service facility, and ITL will pay return ground shipping charges. Warranty service on F21 and F24 units shall be provided by ITL only and ITL will not be responsible for service or repair costs charged by third parties. ITL will not be liable for any damage to the warranted product, and no other warranty is expressed or implied, except as explicitly described. ITL does not warranty any consumable parts, including batteries, fuses, buttons, relays, or housings. This warranty does not include damage caused by improper installation (including ignoring environmental specifications), improper or insufficient maintenance, any modifications, improper operation, or improper software interfacing. The remedies provided herein are the buyer's sole and exclusive remedies. ITL shall not be liable for any direct, indirect, special, incidental, or consequential damages.

## FCC Approval Information

The following information applies to transmitters:

Model F24-J:                      FCC identifier LWN9406F60

This device complies with part 15 of the FCC Rules. Operation is subject to the following two conditions: (1) This device may not cause harmful interference, and (2) this device must accept any interference received, including interference that may cause undesired operation.

The following information applies to receivers:                      Model F24-J



Tested to comply with FCC standards

“For home or office use”

## 2.0 Installation Instructions:

1. The receiver should be mounted in a location that is convenient to the control box and is securely attached to the equipment. The receiver is mounted by drilling four  $\frac{1}{4}$ " (6mm) holes (see diagram below). Mount the receiver using the supplied hardware. It is best to keep the receiver as far away as possible (approximately 6 feet) from variable frequency drives and the motors and cables attached to them to avoid interference.

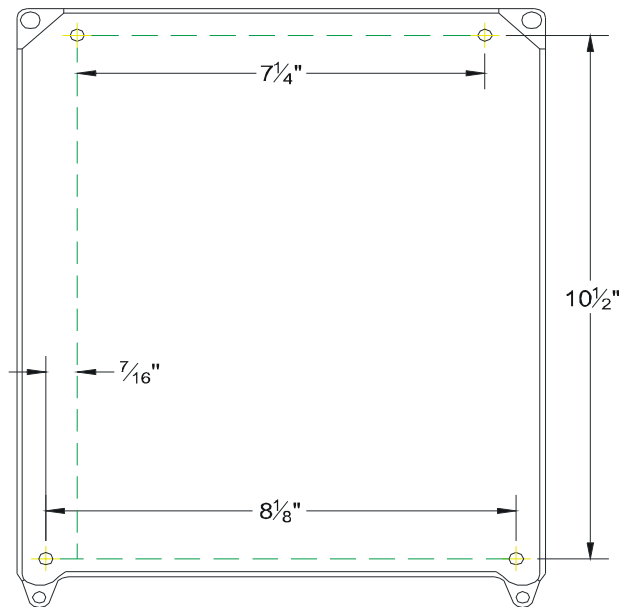

F24-J-RX Receiver Mounting Diagram

2. The receiver wires are numbered. The wires are identified on the label on the top of the receiver.
3. All the contacts in the receiver are “dry” relay contacts. This means that there is no internal source of power to the contacts. You will need to connect the “common” lead for each output or set of outputs that you plan to use to the same power supply that it would be connected to in a corded pendant. For most cranes this wire is X1 (the 120 volt AC control transformer “hot” side). Some cranes have separate hoist/trolley and bridge transformers. In these cases, connect each transformer’s X1 to the function(s) it powers. There is no requirement that the common leads be connected to a 120 volt AC supply- these are “dry” relay contacts; whatever you put into the common wire, comes out each function’s wire when that relay closes. The only restrictions are, do not exceed 10 amps or 250 volts AC. For DC applications call the factory at 1-800-382-3558.

4. Put 4 AA alkaline batteries into each transmitter. To insert the batteries in the F24-J-TX (transmitter), unscrew and open the hinged battery cover on the bottom of the unit. Remove the battery pack. Insert the batteries as indicated on the label inside the battery pack noting polarity markings. Insert the battery pack into the bottom of the transmitter. Replace the cover and tighten the thumbscrew until the cover is fully seated against the transmitter body.
5. Test the system thoroughly before releasing it for use.
6. If the transmitter does not work check battery polarity.

### 3.0 Operation Instructions:

#### 1. Battery Indicator:

The LED on the front of the transmitter indicates the condition of the batteries. It will flash green during operation if the battery power is sufficient, and will flash red if the battery power is low. If the LED is flashing red, or if the operation becomes erratic, or will only work from a short distance, replace **all 4** batteries with new AA alkaline batteries using the procedure given in section 2.4.

#### 2. Fuses

There are seven fuses in the F24-J-RX. There is one fuse in the AC power line that operates the receiver (0.5A, 250V), and one in the internal 12 volt DC supply (1.5A, 250V). There are five fuses in the COM wires (10A, 250V). The fuses on the COM wires are for relay contact protection in the event of a short circuit in the equipment being controlled by the radio. To replace a fuse, push down the fuse cover and turn counter-clockwise ¼ turn with thumb and forefinger or a flat-blade screwdriver. Remove the fuse from the cover and insert a new one of the same rating. Insert the fuse and cover into the fuse holder, press down, and turn clockwise ¼ turn. *For protection from fire hazard, damage, or injury, always replace a blown fuse with one of the same rating.*

#### 3. Start Procedures for the F24-J

1. If the red STOP knob is pushed in, turn it clockwise about 45 degrees to reset it and allow it to pop up. This knob must be in the up position in order to operate the transmitter.
2. Put the green key into its socket in the front of the transmitter.
3. Turn the green key clockwise to the ON position, and then press the green (START) pushbutton. This will engage the mainline contactor and prepare the radio for operation.
4. Use the joysticks and/or pushbuttons to control the equipment.

5. Press the red STOP knob or turn the green key to OFF to stop movement immediately and drop out the mainline contactor.
6. Turn the green key to OFF and remove it whenever the transmitter is not in use to prevent unintentional operation.
7. The receiver has an extra relay labeled R0. Pushing the green start button after the equipment has already been started will close this relay. This relay will not engage the first time the Start pushbutton is pressed when starting up the equipment. See section 8.0 for detailed information on this option.

#### 4.0 Safety:

**EMERGENCY PROCEDURE: In case of emergency, perform these steps IN ORDER.**

1. **Press the red STOP button.**
2. **Turn the green key to OFF position.**
3. **Switch off the main power to the equipment.**
4. **Contact qualified service personnel.**

This manual is intended for the user as a general reference only. Please consult your distributor for specific installation or assistance with technical issues. In an industrial environment, safety must always be a top priority. Persons responsible for installation, operation, and maintenance must make certain that both their actions and the equipment on which they work are safe.

Following are a list of safety rules that must be followed when working with TELECRANE products, as well as cranes and industrial equipment in general. This list is not intended to be all-inclusive. General industrial safety rules must always be followed. If there is any doubt about how to proceed, always take the safest course of action.

- Only qualified personnel who are familiar with the product and who have read these safety instructions should install TELECRANE products.
- Before installing or operating this product, read this manual thoroughly. If you have any questions, please contact ITL.
- All sources of power to the crane or controlled equipment must be de-energized and locked out before installing the unit.
- Before installing the receiver, energize it in a controlled environment (such as an office) where it can be tested and set up properly before it is mounted in the field. If it does not work exactly as intended, fix the problem and test it again.

- Before installation, be certain to understand the electrical functioning of the crane or equipment, including the sequence and relationship of motions and contactors.
- Fall prevention devices should be used when anyone is working at an elevated height.
- The receiver must be securely attached and located where it will not be hit by any moving part of the building, crane, or load.
- The crane or hoist must be equipped with limit switches for each motion and a main power contactor that cuts off all power to the motors of the crane when it is de-energized.
- Special care must be taken for magnets and other load-carrying devices to ensure that if the crane is de-energized the load remains supported.
- The receiver must be located so that it receives sufficient signal strength from the transmitter.
- Operating any piece of equipment in an industrial facility can be dangerous. Adequate training must be provided to operators of cranes or other equipment using a TELECRANE product.
- At least once each shift, check the amount of power remaining in the transmitter batteries. If it is low, change **all four** batteries before beginning operation. Operating the unit with excessively discharged batteries can be unsafe.
- The safety key should be removed from the transmitter whenever it is not in use and should only be issued to authorized personnel.
- All TELECRANE Radio Remote Controls are tested before they leave the factory. However, they should not be used in dangerous situations or in a manner such that damage might result.
- Although the transmitter is very durable and weather-resistant, precautions should always be taken to limit its exposure to weather, physical impact, and corrosives.
- After use, or if the unit will not be used for a long interval, turn off power to the crane or equipment and remove the safety key from the transmitter.
- Remove the batteries from the transmitter if the transmitter will not be used for two weeks or longer.
- Transmitters that are not in use, including spare transmitters, should be stored with batteries removed, and secured to prevent accidental operation.
- Before each shift, check that the limit switches function correctly and that movement corresponds to the button being pressed or joystick being operated on the transmitter.
- Do not use the equipment during lightning storms or high electrical interference conditions.

- In general only authorized service facilities should perform maintenance on this product.
- Ensure that anyone performing maintenance on the unit is thoroughly familiar with its operation.
- Power should be shut off to the crane or equipment before any maintenance begins, unless absolutely required for troubleshooting the unit. When the power is on, use extreme caution. High voltage or unexpected movement could cause death or severe injury.
- Only certified maintenance personnel should attempt a repair more involved than the swapping of printed circuit boards. Improper repair can compromise the built-in safety features and cause unexpected operation and damage.
- This product uses four AA alkaline batteries. When replacing batteries, all four must be replaced at the same time.
- ITL does not recommend use of nickel-cadmium or nickel-metal-hydride batteries due to voltage characteristics that cause a sudden loss of power when discharged. They also have less capacity than alkaline batteries and therefore will not last as long.

#### **5.0 Troubleshooting Common Mistakes In Installation:**

- **Receiver dead:** Is 120 volt AC applied between X1 and X2 wires? These are wires 1 and 2. You must provide both the hot and the neutral sides of the control transformer secondary to power the unit.
- **Relays close but there is no movement from the crane:** Are the COMMON wires hooked up properly? The receivers have “dry” contacts. Even though X1 and X2 have been applied to power the receiver, you still need to apply power to the common side of the relay contacts in order to get power to your contactors. These are the COM wires for each of the outputs on the receiver. Each COM wire is completely isolated from the others as well as the power wires. In most cranes, the COM wires will be connected to the X1 supply.
- **If the transmitter does not work:** Check that all four batteries have sufficient power and verify correct battery polarity as shown on the battery pack.

If you have any problems or questions not covered above, please call ITL at 1-800-382-3558.

## 6.0 Transmitter Function Settings

Function/ Setting	Description /Notes	Available Settings	Default Settings
<b>Second Function of the Start Button</b>	Control button	<ul style="list-style-type: none"> <li>• Normal control of R0</li> <li>• Toggle (on/off) control of R0</li> <li>• Inching (in seconds) <ul style="list-style-type: none"> <li>○ 0.05</li> <li>○ 0.1</li> <li>○ 0.2</li> <li>○ 0.3</li> <li>○ 0.4</li> <li>○ 0.5</li> <li>○ 0.6</li> <li>○ 0.8</li> </ul> </li> </ul>	Normal control of R0
<b>F1 Button</b>	Control button	<ul style="list-style-type: none"> <li>• Normal</li> <li>• Toggle (on/off)</li> </ul>	Normal
<b>1 Button</b>	Control button	<ul style="list-style-type: none"> <li>• Normal, not interlocked</li> <li>• Normal, interlocked with button 2</li> <li>• Toggle (on/off)</li> <li>• On (off is button “2”)</li> </ul>	Normal, interlocked with button 2
<b>2 Button</b>	Control button	<ul style="list-style-type: none"> <li>• Normal, not interlocked</li> <li>• Normal, interlocked with button 1</li> <li>• Toggle (on/off)</li> <li>• Off (on is button “1”)</li> </ul>	Normal, interlocked with button 1
<b>3 Button</b>	Control button	<ul style="list-style-type: none"> <li>• Normal, not interlocked</li> <li>• Normal, interlocked with button 4</li> <li>• Toggle (on/off)</li> <li>• On (off is button “4”)</li> </ul>	Normal, interlocked with button 4
<b>4 Button</b>	Control button	<ul style="list-style-type: none"> <li>• Normal, not interlocked</li> <li>• Normal, interlocked with button 3</li> <li>• Toggle (on/off)</li> <li>• Off (on is button “3”)</li> </ul>	Normal, interlocked with button 3

## 6.0 Transmitter Function Settings Cont.

<b>A Dial</b>	Control dial	On/off	On/off
<b>B Dial</b>	Control dial	<ul style="list-style-type: none"> <li>• A, A+B, B</li> <li>• A, Off, B</li> </ul>	A, A+B, B
<b>C Dial</b>	Control dial	<ul style="list-style-type: none"> <li>• A, A+B, B</li> <li>• A, Off, B</li> </ul>	A, A+B, B
<b>D Dial</b>	Control dial	On/off	On/off
<b>Joystick 1</b>	2-axis (X and Y) joystick controller	<ul style="list-style-type: none"> <li>• 4 directions, 5 or fewer detents* in each direction.</li> <li>• Extensive custom programming available, see Technical Sheet in Section 11.</li> </ul>	4 directions, 5 detents in each direction
<b>Joystick 2</b>	2-axis (X and Y) joystick controller	<ul style="list-style-type: none"> <li>• 4 directions, 5 or fewer detents* in each direction.</li> <li>• Extensive custom programming available, see Technical Sheet in Section 11.</li> </ul>	4 directions, 5 detents in each direction

\* Refer to Section 11 for additional detent settings

## 7.0 Receiver Function Settings

Function/Setting	Description Notes	Available Settings	Default Settings
<b>Auto-Shutdown Time</b>	Elapsed idle time before receiver is automatically shut down	<ul style="list-style-type: none"> <li>• Never</li> <li>• 10 minutes</li> <li>• 20 minutes</li> <li>• 30 minutes</li> <li>• 1 hour</li> <li>• 2 hours</li> <li>• 3 hours</li> <li>• 4 hours</li> </ul>	1 hour
<b>Joystick 1 X-Axis Acceleration Delay</b>	Time between actuation of relays when joystick is moved	• 0 seconds	0.5 seconds
<b>Joystick 1 Y-Axis Acceleration Delay</b>		• 0.3 seconds	
<b>Joystick 2 X-Axis Acceleration Delay</b>		• 0.5 seconds	
<b>Joystick 2 Y-Axis Acceleration Delay</b>		• 1.0 seconds	
		• 1.5 seconds	
		• 2.0 seconds	
		• 3.0 seconds	
		• 4.0 seconds	

## 8.0 Programming options:

- **Auto-shut-down time.** An auto-shut-down feature is available. If the radio has not been used for a period of time the receiver automatically drops out the main line contactor. The default setting is 1 hour. Auto-shut-down times can be set between 0 and 4 hours. Typical selections are available on the programming data sheets in the back of this manual.
- **Pushbutton options.** Each pushbutton is set by default to momentary (relay closes when a button is pressed and opens when released), and interlocked in opposed motion pairs (UP-DOWN, EAST-WEST, SOUTH-NORTH). When set as momentary, they can be set as un-interlocked. They can also be set as toggle (press once to close relay, press again to open) or as On-Off pairs (press On to close relay, press Off to open relay). When programmed as toggle or On-Off, they will be set as controlled by Stop (opening automatically when the STOP button is pressed). They can be reprogrammed by the factory for uncontrolled by Stop (unaffected by STOP button); please call for more information.
- **Acceleration delay.** Delay between actuation of relays for each of the detents of the joysticks can be programmed. This delay time can be set between 0 and 4 seconds; default is 0 seconds. Typical selections are available on the programming data sheet.
- **R0 function.** The R0 relay operates only when the START button is pushed after the unit has already been started. It is by default set to momentary (closed when START button is pressed, open when released). It can also be set to toggle (push the START button once to close, then push the button again to open), or inching (does not activate the R0 relay, but instead only allows pushbuttons pressed, after pushing the START button, to remain on for a preset length of time, no matter how long the button is held). For inching, the inch time may be set to a minimum of 0.05 seconds or anywhere from 0.1 to 0.8 seconds in 0.1-second increments. Typical selections are available on the programming data sheet.

Call Factory for more information 1-800-382-3558.

## 9.0 Product Options

- Below are the legend sets that are available to change the button labels of the F24 series transmitters.

Part # 22A3001



Part # 22A3003



- An antenna kit is available for the joystick models effectively extending the range to 1500+ feet (line of sight). Call factory for details. 1-800-382-3558
- Cables are available as well for mounting the stock antenna outside an enclosure. Call Factory for details. 1-800-382-3558

**This Page Intentionally Left Blank**

# 10.0 F24-J Wiring Diagram (Standard)

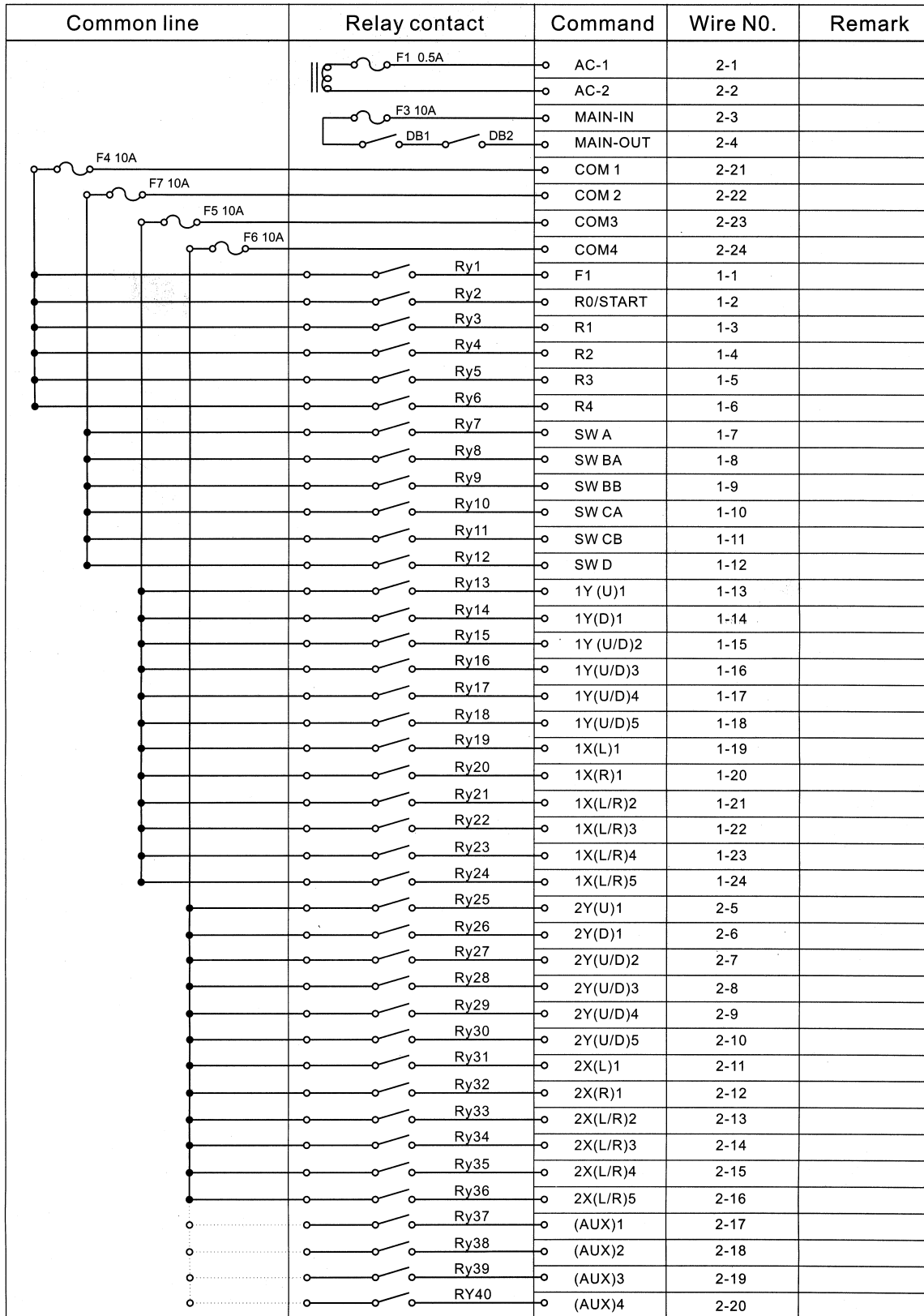

**This Page Intentionally Left Blank**

# 11.0 Programming and button labeling

## Custom labels for F24-J

The words in bold appear on the joystick motion if you do not fill in the squares below.

<b>WEST</b> <input type="checkbox"/> <input type="checkbox"/> <input type="checkbox"/> <input type="checkbox"/> <input type="checkbox"/>	<b>EAST</b> <input type="checkbox"/> <input type="checkbox"/> <input type="checkbox"/> <input type="checkbox"/> <input type="checkbox"/>	<b>aux DOWN</b> <input type="checkbox"/> <input type="checkbox"/> <input type="checkbox"/> <input type="checkbox"/> <input type="checkbox"/>	<b>aux UP</b> <input type="checkbox"/> <input type="checkbox"/> <input type="checkbox"/> <input type="checkbox"/> <input type="checkbox"/>
---	---	---	---

	<p><b>NORTH</b> <input type="checkbox"/><input type="checkbox"/><input type="checkbox"/><input type="checkbox"/><input type="checkbox"/></p> <p><b>SOUTH</b> <input type="checkbox"/><input type="checkbox"/><input type="checkbox"/><input type="checkbox"/><input type="checkbox"/></p>
	<p><b>UP</b> <input type="checkbox"/><input type="checkbox"/><input type="checkbox"/><input type="checkbox"/><input type="checkbox"/></p> <p><b>DOWN</b> <input type="checkbox"/><input type="checkbox"/><input type="checkbox"/><input type="checkbox"/><input type="checkbox"/></p>

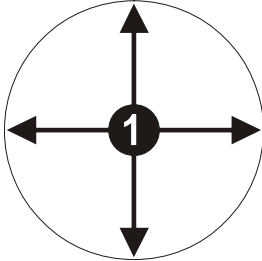
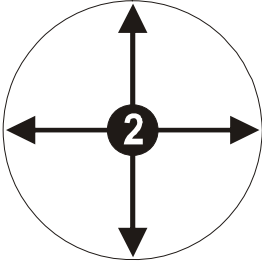
## Restrict maximum speed position of any motion

Circle the last detent that the that motion can achieve. Default detent is all the way through to the 5th step.

	<p>If you wish to eliminate all the detents from any of the 4 motions write NONE above the motion's arrow instead of circling a number.</p>
	

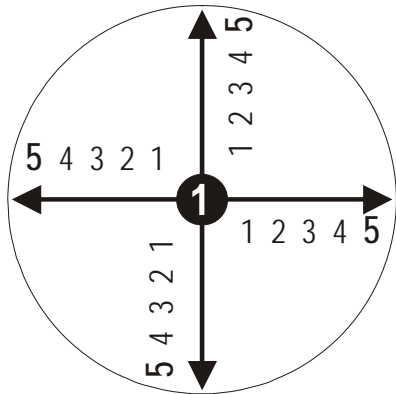
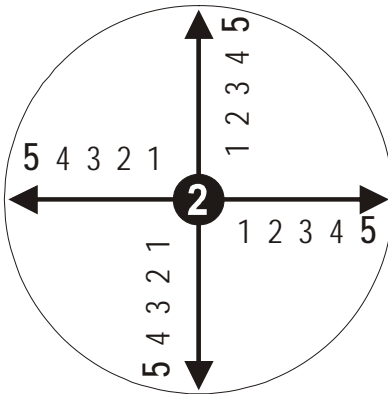
## Customize travel path of joystick

To customize where the joystick can travel circle one of the drawings below for each joystick or fill in the blank circle with the path desired. The fully black circle represents the default setting of complete 360 degree range of motion.

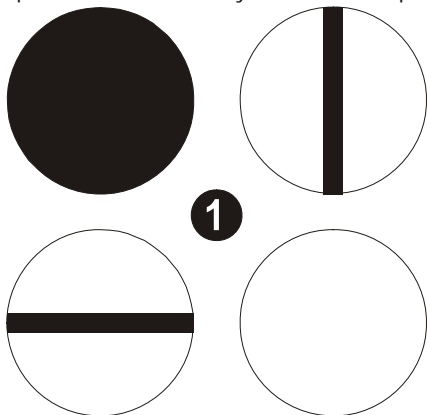
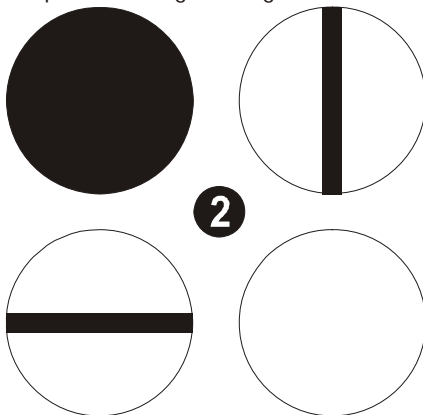
 <p><b>1</b></p>	 <p><b>2</b></p>
---	--

**This Page Intentionally Left Blank**

# Button and Dials Programming Sheet: F24-J

**Auto Shut Down time**  
Default setting of 1 hour

never       1 hour  
 10 minutes     2 hours  
 20 minutes     3 hours  
 30 minutes     4 hours

**F1**      **Start**

Normal  
 Toggle (on/off)  
      Controlled by stop  
      Not controlled by stop

**1**

*normal, interlocked with button "2"*

Normal, not interlocked  
 Toggle (on/off)  
 On (off is button "2")  
      Controlled by stop  
      Not controlled by stop

**2**

*normal, interlocked with button "1"*

Normal, not interlocked  
 Toggle (on/off)  
 Off (on is button "1")  
      Controlled by stop  
      Not controlled by stop

**3**

*normal, interlocked with button "4"*

Normal, not interlocked  
 Toggle (on/off)  
 On (off is button "4")  
      Controlled by stop  
      Not controlled by stop

**4**

*normal, interlocked with button "3"*

Normal, not interlocked  
 Toggle (on/off)  
 Off (on is button "3")  
      Controlled by stop  
      Not controlled by stop

The A & B associated with dial B pertain to only dial B. The A & B associated with dial C pertain to only dial C.

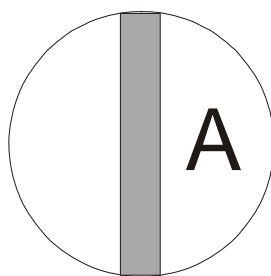

**A**

On / Off  
 Controlled by stop  
 Not controlled by stop

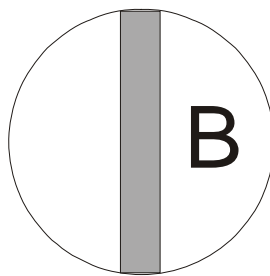

**B**

A, A+B, B  
 A, OFF, B  
 Controlled by stop  
 Not controlled by stop

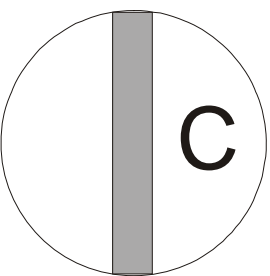

**C**

A, A+B, B  
 A, OFF, B  
 Controlled by stop  
 Not controlled by stop

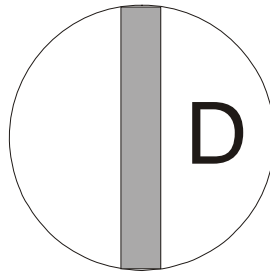

**D**

On / Off  
 Controlled by stop  
 Not controlled by stop

**This Page Intentionally Left Blank**

# Custom relay configuration sheet for model: F24-J

## Standard Configurations

	WEST					EAST					
	5	4	3	2	1	0	1	2	3	4	5
1X1	X	X	X	X	X						
1X2							X	X	X	X	X
1X3	X	X	X	X				X	X	X	X
1X4	X	X	X						X	X	X
1X5	X	X								X	X
1X6	X										X

Acceleration delay in seconds: 0.0, 0.3, 0.5, 1.0, 1.5, 2.0, 3.0, 4.0

## Custom Configurations

	WEST					EAST					
	5	4	3	2	1	0	1	2	3	4	5
1X1											
1X2											
1X3											
1X4											
1X5											
1X6											

## SOUTH NORTH

	SOUTH					NORTH					
	5	4	3	2	1	0	1	2	3	4	5
1Y1	X	X	X	X	X						
1Y2							X	X	X	X	X
1Y3	X	X	X	X				X	X	X	X
1Y4	X	X	X						X	X	X
1Y5	X	X								X	X
1Y6	X										X

Acceleration delay in seconds: 0.0, 0.3, 0.5, 1.0, 1.5, 2.0, 3.0, 4.0

## SOUTH NORTH

	SOUTH					NORTH					
	5	4	3	2	1	0	1	2	3	4	5
1Y1											
1Y2											
1Y3											
1Y4											
1Y5											
1Y6											

## AUX DOWN AUX UP

	AUX DOWN					AUX UP					
	5	4	3	2	1	0	1	2	3	4	5
2X1	X	X	X	X	X						
2X2							X	X	X	X	X
2X3	X	X	X	X				X	X	X	X
2X4	X	X	X						X	X	X
2X5	X	X								X	X
2X6	X										X

Acceleration delay in seconds: 0.0, 0.3, 0.5, 1.0, 1.5, 2.0, 3.0, 4.0

## AUX DOWN AUX UP

	AUX DOWN					AUX UP					
	5	4	3	2	1	0	1	2	3	4	5
2X1											
2X2											
2X3											
2X4											
2X5											
2X6											

## DOWN UP

	DOWN					UP					
	5	4	3	2	1	0	1	2	3	4	5
2Y1	X	X	X	X	X						
2Y2							X	X	X	X	X
2Y3	X	X	X	X				X	X	X	X
2Y4	X	X	X						X	X	X
2Y5	X	X								X	X
2Y6	X										X

Acceleration delay in seconds: 0.0, 0.3, 0.5, 1.0, 1.5, 2.0, 3.0, 4.0

## DOWN UP

	DOWN					UP					
	5	4	3	2	1	0	1	2	3	4	5
2Y1											
2Y2											
2Y3											
2Y4											
2Y5											
2Y6											

### Notes:

\*The default relay configuration chart is on the left side. If you want the relays to close in different combinations than the default settings then mark the appropriate chart to the right with X's in the appropriate squares.

**This Page Intentionally Left Blank**